

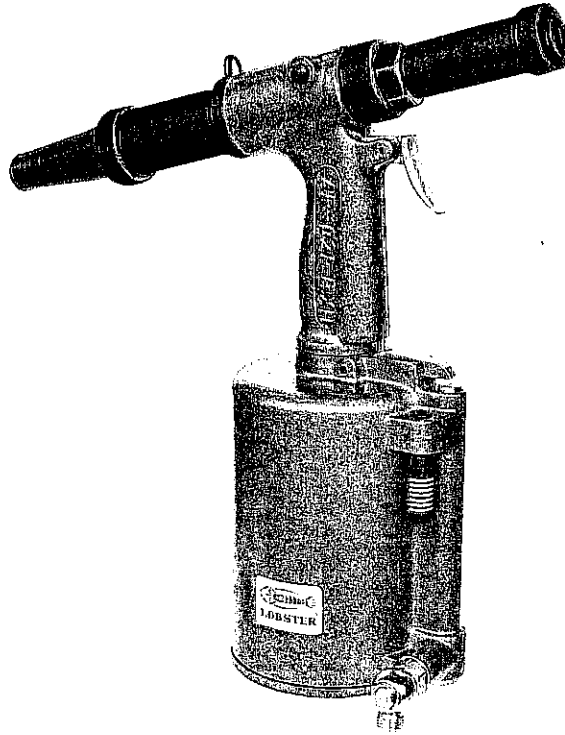

# INSTRUCTION MANUAL



**AR-021EXH**

**Lobster® Tools**

## INTRODUCTION

This manual describes the various features and maintenance instructions of the new AR-021EXH.

**AR-021EXH** power tool offers you the latest "noiseless & shockless" technology in a compact easy-to-use package.

**Before** using this riveter, it is recommended that you read this manual carefully to ensure effective and satisfactory operation of your riveting gun.

If you need further assistance, contact your Lobster dealer or write us directly.

## SAFETY INSTRUCTIONS

This AR-021EXH power riveter shall be used to install MAGNA-LOK® blind fasteners and other structural blind rivets 1/4"(6.4mm) in all materials including stainless. (HUCK MAGNA-LOK® — A Thiokol Company)

It shall at all times be operated in accordance with recognised safe workshop practice. The tool must be maintained in a safe working conditions at all times.

Do not dismantle this tool without prior reference to the dismantling instructions contained in this manual. The precautions to be observed when using this tool must be explained by the customer to all operators. Specific points to be observed are:

1. Do not operate this tool that is directed towards any person.
2. Keep the air pressure applied to this tool within 85-92 P.S.I. (6-6.5kg/cm<sup>2</sup>).
3. The tool shall not be operated unless an undamaged deflector (#24) is fitted.
4. No equipment shall be used with this tool other than that recommended and supplied by Lobster.
5. Always disconnect the air supply from the tool before attempting to adjust, change nosepiece or dismantle tool components.
6. Do not operate the tool without frame head (#2).
7. Ensure that the silencer (#51) at the air exhaust do not become blocked or covered.
8. Care shall be taken to ensure that spent mandrels are not allowed to create a hazard.
9. Any modification to tools and equipment undertaken by the customer shall be at his entire responsibility. Lobster will be pleased to advise upon any proposed modification.
10. Excessive priming of hydraulic oil in tools should be avoided.
11. The tool shall be examined at regular intervals for damage and function. Any question regarding the correct operation of tools and operator safety should be directed to Lobster.
12. Always wear eye-protection when using this tool.

## DESCRIPTION

AR-021EXH hydro-pneumatic power tool has been designed to install MAGNA-LOK<sup>®</sup> and structural pull stem break mandrel blind rivets in sizes.

1/4"  
(6.4mm)

In aluminum, copper, steel, monel & stainless, by a simple change over of nosepiece, without any adjustments.

## SPECIFICATIONS

TRACTION POWER	:	1700kg (3740Lbs): 16,637N
STROKE	:	22mm (0.866")
WORKING AIR PRESSURE	:	85-92P.S.I. (6-6.5kg/cm <sup>2</sup> )
AIR CONSUMPTION PER CYCLE	:	4.6 litre/rivet (0.162ft <sup>3</sup> )
WEIGHT	:	2.9 kg (6.42 Lbs)

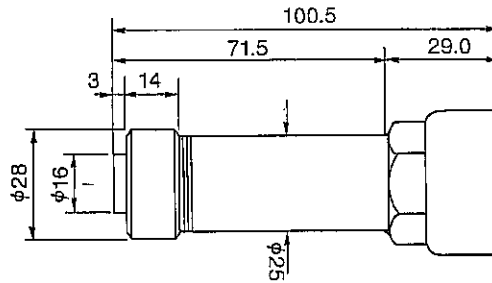

Frame head dimensions (mm)

## PRINCIPLE OF OPERATION

When the tool is connected to a proper air supply and the trigger is depressed, air pressure acts upon the air piston and moves it upward. The piston rod serve as a hydraulic piston and acts on a volume of hydraulic oil in the handle. Pressurized hydraulic oil is forced into the head to move the oil piston in conjunction with the nose assembly to start blind rivet installation.

The built-in oil damper in the hydraulic system reduces the weight & size of

mechanical shock exerted during mandrel break. When the blind rivet installation is completed, the trigger is released.

The return springs behind the oil piston returns it to its starting position. Hydraulic oil is forced out of the head and returns the hydraulic oil and air piston to their starting positions. The air in the air cylinder is also forced out through the silencer, softens the noise created at the air exit due to sudden air pressure.

## PREPARING FOR OPERATION

Daily, before putting the tool into service, comply with instructions under "good service practices".

Always bleed air line to clear it of all accumulated dirt or water before connecting air supply to tool.

An air supply of 85-92 P.S.I. (6-6.5kg/cm<sup>2</sup>) must be available.

Ensure tool is equipped with the correct nosepiece to fit the rivet being installed.

## MAINTENANCE

### AIR SUPPLY SYSTEM

AR-021EXH tool is designed to operate with a compressed air supply between 85 P.S.I. and 92 P.S.I. (6-6.5kg/cm<sup>2</sup>). Pressure regulators should be used to limit the air pressure where the air supply exceeds the maximum recommended air pressure. Oiling and filtering systems are used and fitted within 10' (3meters) of the tool. This ensures maximum tool life and minimises tool malfunctions.

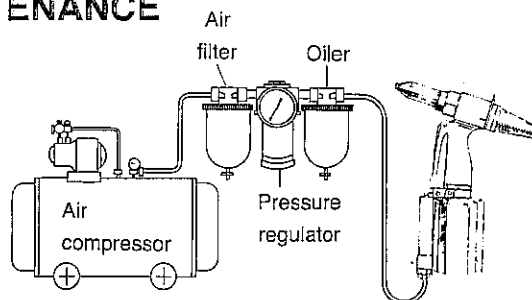

the tool. This ensures maximum tool life and minimises tool malfunctions.

## GOOD SERVICES PRACTICES

Regular inspection and immediate repair of minor faults will keep the tool and nose assembly operating efficiently and prevent down time. Daily before putting the tool into service, observe the following practices:

1. If a filter-regulator-lubricator unit is not being used, remove hose fitting from air inlet and drop in a few drops of clean light oil.
2. Blow out airline to remove dirt and water before connecting air hose to tool.
3. Clean nose assemblies frequently.
4. Do not abuse the tool by dropping it, using it as a hammer or otherwise causing unnecessary wear and tear.

## NOSE ASSEMBLY

AR-021EXH power tool leaves the factory fitted with 1/4" (6.4mm) MAGNA-LOK® nosepiece. Before placing rivets ensure that the correct nosepiece is fitted for the size of rivet being installed.

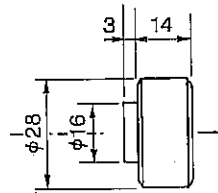

## PROCEDURE FOR CHANGING NOSE PIECE

1. Disconnect air supply to tool.
2. Simply screw on the corrected nosepiece.
3. Reconnect air supply to tool.
4. Tool should now be ready for use.

## OIL REFILL

After considerable use, the stroke of this power tool AR-021EXH may be reduced and the fastener not fully placed by one operation of the trigger. To restore to full stroke the following procedure should be adopted:

### IMPORTANT

1. Disconnect air from main supply.
2. All operations to be carried out on a clean bench, with clean hands, in a clean area.
3. When priming the AR-021EXH power tool, hydraulic oil supplied by "Lobster" should be used.
4. Ensure that the priming pump (#87) is free from foreign matter and that the oil is perfectly clean.
5. Care should be taken at all times that foreign matter does not enter the power tool, or serious damage, may result.
6. Every care should be taken to keep the oil free from air bubbles when priming.

### TO REPRIME

1. Thoroughly clean the exterior of tool.
2. Lay power tool horizontally with the frame head (#2) mounted, and remove the top bleed plug (#16) and seal (#15).
3. Fill priming pump (#87) with oil. Depress pump slightly to expell air from priming pump.
4. Screw priming pump lightly on the tool at the base of bleed plug and depress priming pump handle until oil issued freely into it. Repeat twice until you feel back pressure.
5. Excessive priming of hydraulic oil is regulated by the return spring action behind the oil piston and the excess oil will flow back into the pump upon release.
6. Remove the priming pump, and replace top bleed plug and seal.

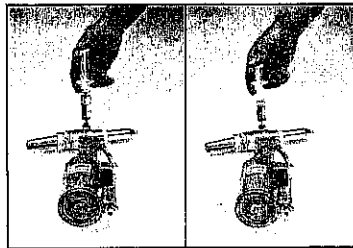

Quick oil refill

# SERVICING PROCEDURE

Regular servicing should be carried out. A comprehensive inspection should also be performed annually or every 200,000 cycles.

## CAUTION

The air line must be disconnected before any dismantling is attempted.

To dismantle, proceed as follows.  
Assembly is reverse where otherwise stated.

## JAW (QUICK CHANGE JAW MECHANISM)

1. Unscrew frame head (#2).
2. Hold down collar (#7), unscrew jaw case head (#3).  
And, dropout jaw pusher spring (#8) jaw pusher (#5) and a pair of jaws (#4).
3. Inspect jaw and clean all parts using brush (#83).  
Renew if worn or damaged.
4. To reassemble, is reverse. Care should be taken that the collar (#7) is properly locked onto the grooves on the jaw case head (#3).
5. Soon after assembly, connect the tool to air supply and try several idle strokes to confirm smooth operation of the tool before use.

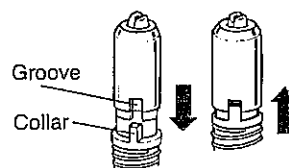
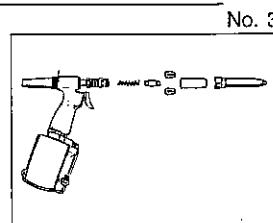
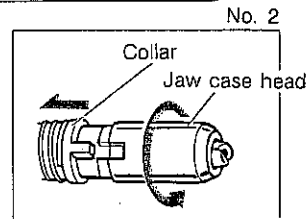
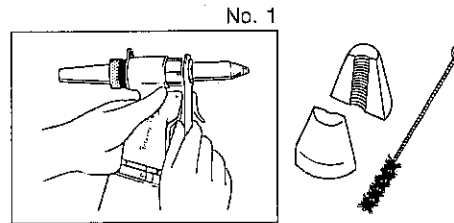

# COMPLETE DISASSEMBLY

## 1. FRAME HEAD

- \* Remove jaw as discussed in the jaw servicing procedure.
- \* Drive out spring pin (#11) with punch out keys (#88), this will loosen the stopper (#10). And unscrew the jaw case (#6) and remove collar (#7), collar spring (#9).

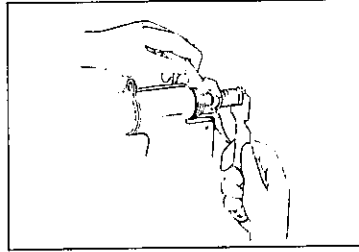

## 2. AIR CYLINDER

- \* Invert the tool and unscrew the cylinder cap (#50) and pull out air piston (#47) in a straight line with suitable pliers. Care should be taken not to scratch the air piston rod. And drain off the hydraulic oil.
- \* Remove the top bleed plug (#16).

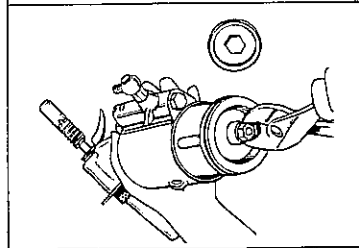
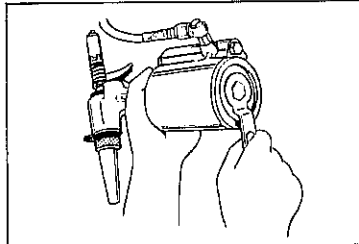

## 3. OIL CYLINDER

- \* Remove deflector (#24) by unscrewing the safety cap nut (#25).
- \* Unscrew frame cap (#23) and remove return springs (#20) along with hanger clip (#22) & push out oil piston (#17).

- \* Drop out valve pusher (#36), valve pusher spring (#38) by inverting the tool.

- \* Unscrew end plug (#45) and drop out valve spring (#43), valve ball (#42) and valve sleeve (#40).

## 4. TRIGGER & VALVE

- \* Drive out spring pins (#32 & #33) and remove trigger linkage.

- \* Remove E-retaining ring (#57) and hinged joint (#56).

- \* Unscrew the male connector (#54).

## 5. SILENCER

- \* Simply unscrew silencer (#5†) using spanner

## 6. FRAME & AIR CYLINDER SEPARATION

- \* Drive out slotted pin (#34), and unscrew frame lock nut (#31) using 32mm socket wrench and separate the frame (#14) from air cylinder (#30).

## ASSEMBLY

Before assembling, inspect all parts and replace if necessary. Clean all parts thoroughly with mineral spirits and lubricate with light grease. Must not forget to grease the inner walls of air/oil cylinders.

A good practice to follow is to replace all 'O'-rings and light springs and valve, whenever the tool is disassembled for any reason.

Then assemble, taking care not to damage the 'O'-rings, frame, air & oil cylinder housing.

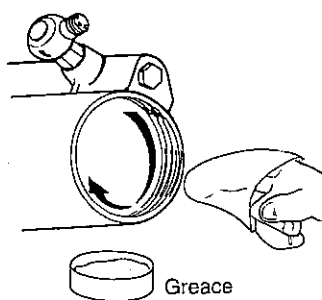

## FILLING THE TOOL

1. Without air piston assembly (#46 thru 48) and fill frame (#14) cavity with clean 'Lobster' hydraulic oil or equivalent, until fluid is level with top "O"-ring (#12) using filler bottle (#86).
  2. Insert air piston assembly (#46 thru 48) and push it down all the way 3 or 4 times.
  3. Carefully push on the air piston (#47) until solid back pressure is noted.
  4. Assemble air cylinder cap (#50) and 'O'-ring (#49) and tighten with wrench or spanner A (#81).
- It is important to check to see the tool is overfilled with oil, proceed as follows:**
5. Remove top bleed plug (#16) to drain off the excess oil and air bubbles if any during filling the tool. Assemble top bleed plug (#16 & 15) and tighten.

### HYDRAULIC OIL REQUIREMENTS

Whenever priming is necessary, the hydraulic oil should be obtained from "Lobster" agent or distributor in your town. If this is not possible, a good quality mineral oil with the following properties should be used:

Viscosity ISO : VG46  
Viscosity Index : 113  
Viscosity at 40°C : 46 c.s.t.  
Viscosity at 100°C : 7.06 c.s.t.  
Flash Point : 228

Fully approved oils are : Shell Tellus No.46  
Esso Teresso No.46  
Mobil D.T.E. 25 Oil (Medium)

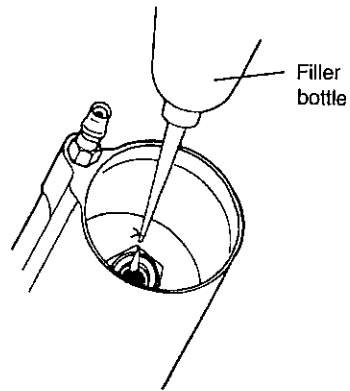

Lobster policy is one of continuous development and as such specifications shown in these document may be subject to change which may be introduced after publication.

For the latest detailed information contact your nearest 'Lobster' representative or write direct to LOBSON Co., Ltd., Osaka, Japan.

## TROUBLE SHOOTING

TOOL MALFUCTION	CAUSE	CORRECTIVE ACTION
1. Loss of stroke	1. Due to Jaw Slip. Jaw slip is indicated by the lack of teeth impressions on broken rivet mandrels.  2. Due to loss of Hydraulic oil.	The Jaws may be worn or merely clogged, replace or clean as necessary. Proceed as follow to service Jaws.  To restore to full stroke proceed as follows to repriming.
2. Continued loss of stroke	Due to worn Hydraulic seals	Replace all the seals in the parts kit #105
3. Tool fails to operate when trigger is depressed	Incomplete or defective valve assembly	Check and replace defective parts (# 35 thru 45)
4. Tool will not break rivet mandrel	1. Improper nosepiece assembly.  2. Low air pressure.	Check with proper nosepiece  Set to 85 – 92 P.S.I.
5. Oil leaking from the front or the back of the oil piston.	1. This is caused by the worn seals.  2. Tool is over filled.	Replace all seals (#18 & 19) and (#12 & 13)  Unscrew top bleed plug and drain off excess oil.
6. Air leaking from riveter trigger valve	Due to worn seal (#37) and that the ball valve (#42) is sitting incorrectly.	Replace worn seal and reassemble valve.

# OUTLINE DIMENSIONS

AR-021-EXH

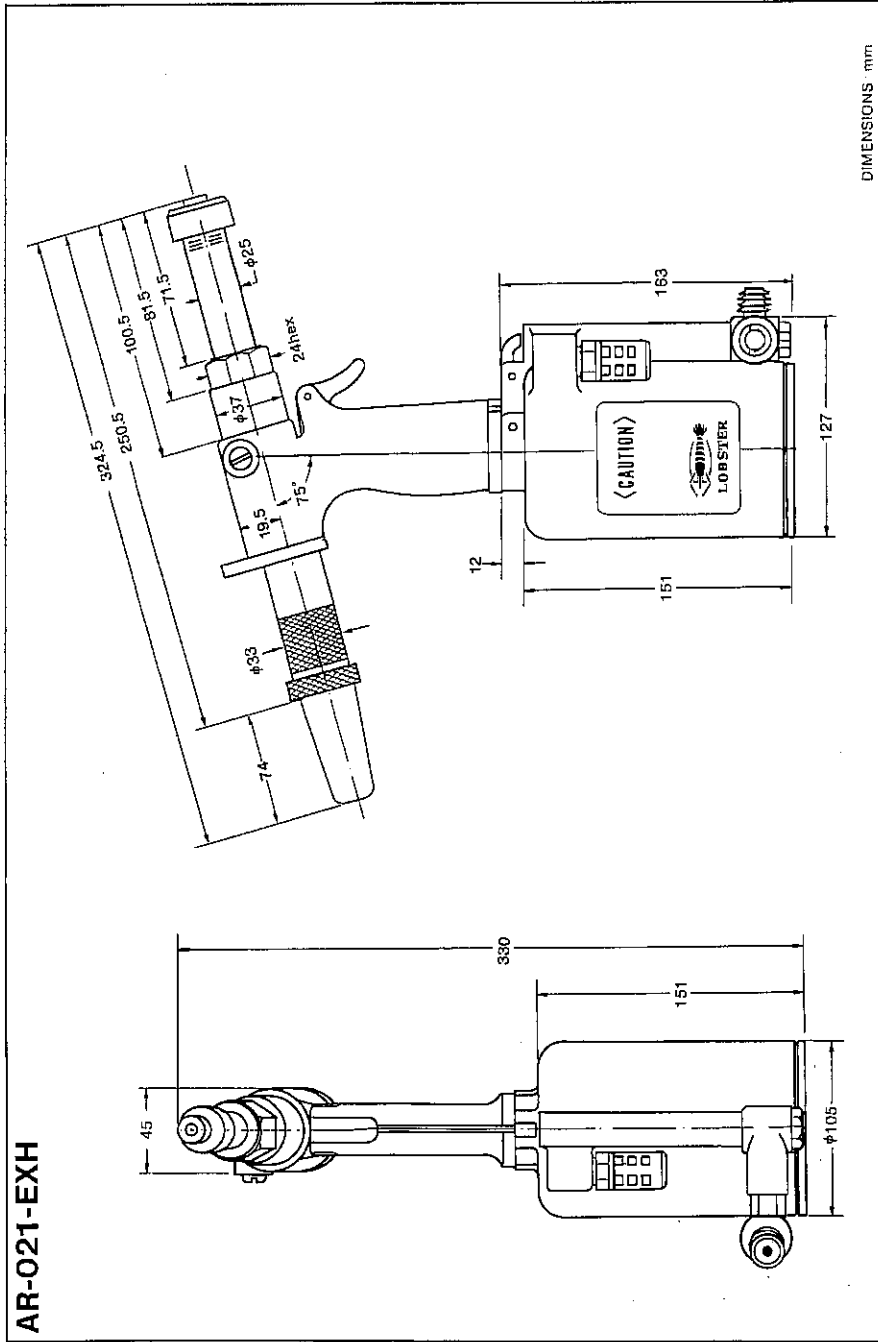

## List of Errata

Thank you very much for your purchase of "LOBSTER" brand Air Riveter AR-021EXH.  
 In this instruction manual, some wrong descriptions are shown. Following is the list of errata.

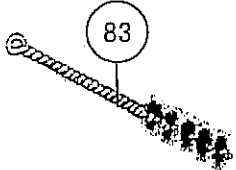
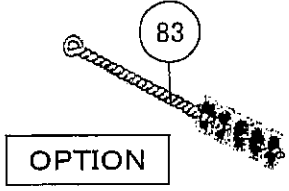
Page	Line	Wrong Description	Correct Description
13	INDEX NO.54	12130 Double Male Connector	42479 Double Male Connector
	INDEX NO.56	10294 Hinged (Rotary) Joint	42501 Hinged (Rotary) Joint
14	INDEX NO.83	10143 Cleaning Brush	10143 Cleaning Brush 《OPTION》
EXPLO-DE VIEW			

MANUFACTURER  
**LOBTEX CO.,LTD.**  
 (Formerly "LOBSTER" TOOL CO., LTD.)  
**International Division**  
 9-10,Hyotan-yama-cho,Higashi Osaka City,Osaka 579-8051 Japan  
 Telephone : +81 (729)81-7466 / Telefacs : +81 (729)81-9420  
 URL <http://www.riveter.com> e-mail: [lobtex@riveter.com](mailto:lobtex@riveter.com)

## PARTS LIST

INDEX NO	CODE NO	PART NAME
01	15937	Nose Piece (nose assembly) for Magna-Lok® (1/4, 6.4mm)
02	15925	Frame Head
03	10447	Jaw Case Head (H)
04	10493	Ultra Jaws (H) (pair)
05	10224	Jaw Pusher (H)
06	12167	Jaw Case
07	10448	Collar for Jaw Case
08	10210	Jaw Pusher Spring
09	10449	Collar Spring
10	12176	Retainer Collar
11	10147	Spring Pin (3 x 6mm)
12A	10434	O-Ring P-14
13A	10435	Back-up Ring P-14
12B	12193	O-Ring P-12.5
13B	12194	Back-up Ring P-12.5
14U	15940	Frame Unit (includes 12 & 13)
15	12120	O-Ring P-5
16	12135	Bleed Plug
17	12166	Oil Piston
18	10207	O-Ring P-24
19	10208	Back-up Ring P-24
20	10438	Return Spring
21	10221	O-Ring S-28
22	15917	Hanger Clip (black)
23	15960	Frame Cap (black)
23A	12174	Frame Cap Sleeve
24	14051	Deflector (Safety Cap)
25	15945	Safety Cap Nut (black)
26	10135	Trigger, Short
27	10202	Connector
28	10450	Trigger Lever

HUK MAGNA-LOK® — A Thokol Company

INDEX NO	CODE NO	PARTS NAME
29	10147	Spring Pin (3 x 6mm)
30	14462	Air Cylinder only
31	10425	Frame Lock Nut
32	10144	Spring Pin (3 x 22mm)
33	10145	Spring Pin (3 x 18mm)
34	14154	Slotted Pin (4 x 31mm)
35	10219	O-Ring P-9
36	10442	Valve Pusher
37	12120	O-Ring P-5
38	10453	Valve Pusher Spring
39	10274	O-Ring P-10
40	10441	Valve Sleeve
41	12120	O-Ring P-5
42	10247	Valve (Steel Ball 8.0mm)
43	10444	Valve Spring
44	10152	O-Ring S-14
45	10440	End Plug
46	10452	O-Ring P-85
47	14276	Air Piston Unit (includes 48 Bumper)
48	10114	Bumper (Rubber Cushion)
49	10445	O-Ring G-95
50	10427	Air Cylinder Cap
51	14355	Air Silencer
52	14359	Air Silencer Plug
53	10151	O-Ring S-10
54	12130	Double Male Connector
55	10149	O-Ring P-7
56	10294	Hinged (Rotary) Joint
57	10285	E-type Retaining Ring E-7
80	15905	Decal, Caution
81	12136	Spanner 'A'

## PARTS LIST

INDEX NO	CODE NO	PARTS NAME
82	10218	Spanner 'B'
83	10143	Cleaning Brush
84	10140	Air Hose Joint 1/4
85	10139	Air Hose Joint Nut 1/4
86	10012	Hydraulic Oil (Bottle)
87	14142	Priming Pump (injector)
88	12175	Punch Out Key

# EXPLODE VIEW AR-021EXH

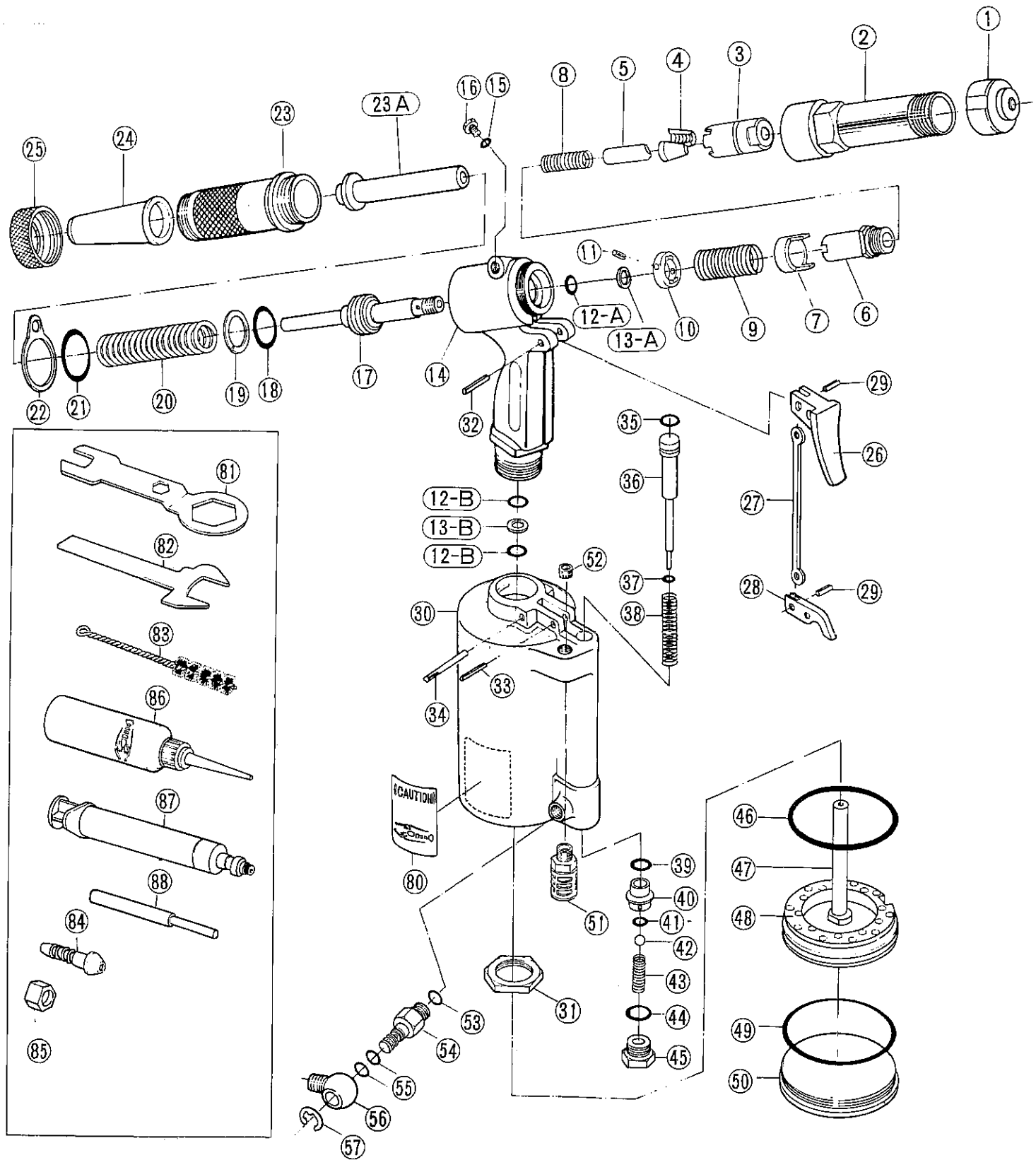

## WARRANTY & SERVICE

LOBSTER® WARRANTS THAT GOODS COVERED BY THIS MANUAL WILL CONFORM TO APPLICABLE SPECIFICATIONS AND DRAWINGS AND THAT SUCH GOODS WILL BE MANUFACTURED AND INSPECTED ACCORDING TO GENERALLY ACCEPTED PRACTICES OF COMPANIES MANUFACTURING INDUSTRIAL TOOLS. THERE ARE NO WARRANTIES WHICH EXTEND BEYOND THE FOREGOING.

THE LIABILITY OF LOBSTER® ON PARTS FOUND TO BE DEFECTIVE IS LIMITED TO RE-WORK OR THE REPLACEMENT OF SUCH GOODS AND IN NO CASE TO EXCEED THE INVOICE VALUE OF THE SAID GOODS. UNDER NO CIRCUMSTANCES WILL LOBSTER® BE LIABLE FOR DAMAGES OR COSTS INCURRED BY THE BUYER OR SUBSEQUENT USER IN RE-PAIRING OR REPLACING DEFECTIVE GOODS.

ROUTINE MAINTENANCE AND REPAIR OF LOBSTER® RIVET TOOLS CAN BE PERFORMED BY AN AVERAGE MECHANIC.

HOWEVER, IF YOU HAVE A LOBSTER® RIVET TOOL THAT IS IN NEED OF MAJOR REPAIR WE RECOMMEND THAT IT BE SENT DIRECTLY TO US POSTAGE PAID FOR SERVICE AT A REASONABLE CHARGES.

MANUFACTURER

 **LOBTEX CO., LTD.**

(Formerly "LOBSTER" TOOL CO., LTD.)

OSAKA, JAPAN