

AR2000MV PARTS TABLE

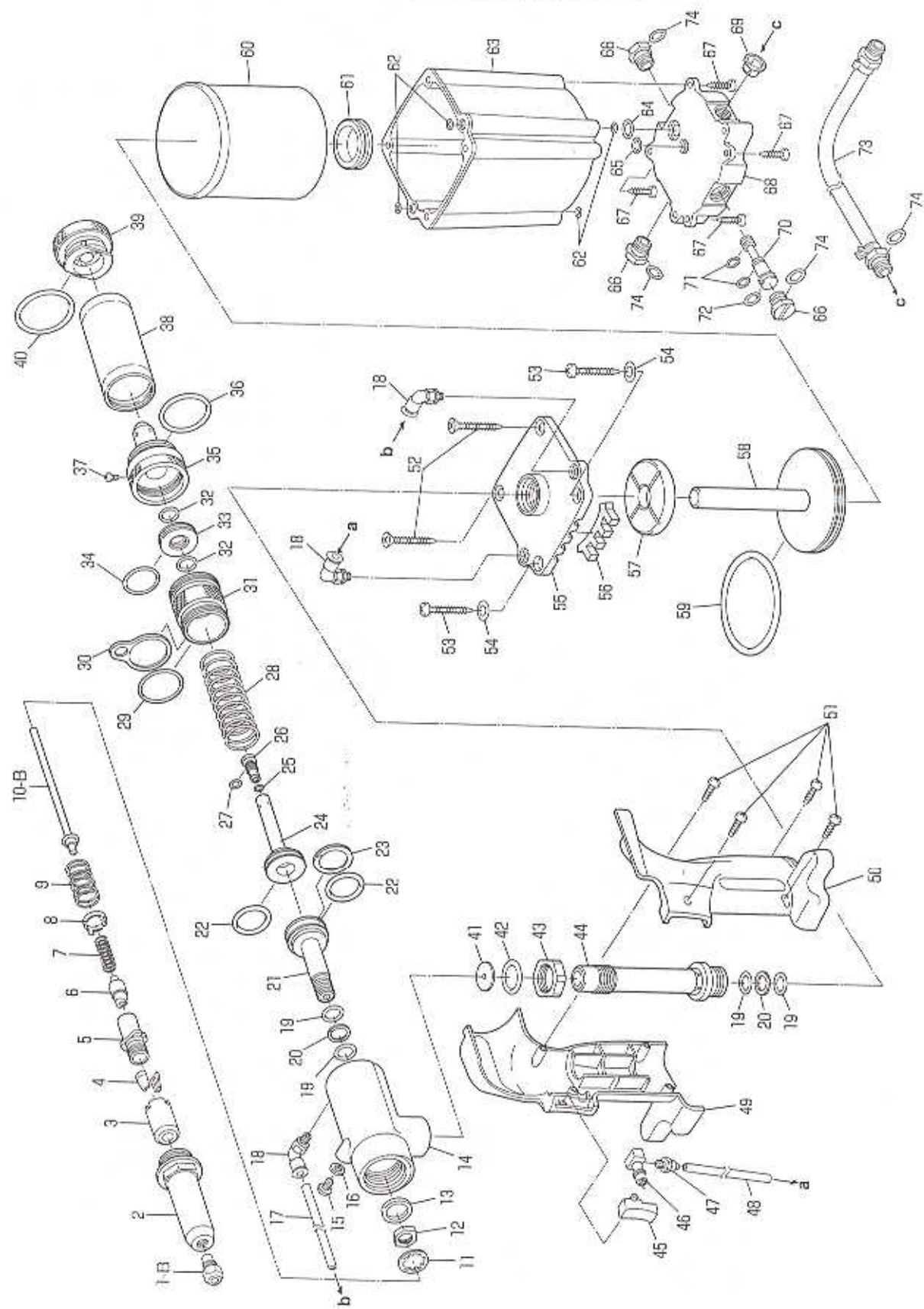

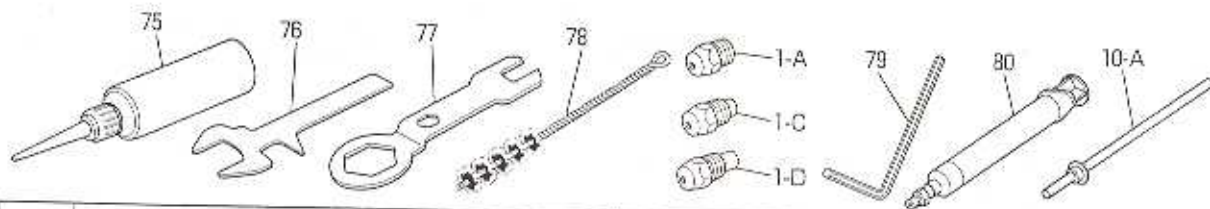

Index No.	Part name	Code No.	Index No.	Part name	Code No.
1-A	Nosepiece 'S' 2.4 (3/32)	10027	38U	Mandrel Tank unit (with cap)	29838
1-B	Nosepiece 'S' 3.2 (1/8)	10028	39	Tank cap (with O-ring)	29703
1-C	Nosepiece 'S' 4.0 (5/32)	10029	40	O-ring P-34	24311
1-D	Nosepiece 'S' 4.8 (3/16)	10030	41	Shock plate	29378
2	Frame head 'M'	29332	42	O-ring P-18 (1B)	29617
3	Jaw case head	10280	43	Aluminum lock nut	29381
4	Ultra jaws (pair) 'M'	10281	44	Oil sleeve unit	29633
5	Jaw case 'M'	10279	45	Switch	29348
6	Jaw pusher	10132	46	Valve sleeve	29350
7	Jaw pusher spring	10133	47	Terracin connector	29351
8	Jaw case collar	10286	48	Polyurethane tube 105 mm	29352
9	Collar spring	10287	49	Frame cover 'R'	29338
10-A	Guide pipe 'A'	29659	50	Frame cover 'L'	29339
10-B	Guide pipe 'B'	29661	51	Pan head tapping screw 3×10	29340
11	Lock washer	10148	52	Flat head tapping screw 5×35	29367
12	Jaw case lock nut	10113	53	Pan head tapping screw 5×35	29608
13	Stop ring	23834	54	Flat washer No.5	29609
14	Frame unit 'M'	29627	55	Cylinder top (with muffler)	29634
15	Bleed plug (Hexagon socket head cap screw)	29337	56	Muffler	29377
16	Pack seal 6 mm	10355	57	Rubber cushion	29358
17	Polyurethane tube 205 mm	29353	58	Air piston unit 'M'	29635
18	Connector	29354	59	O-ring P-60	10134
19	O-ring P-12	10128	60	Cylinder cup 'M'	29360
20	B-ring P-12	10129	61	Grommet	29361
21	Oil piston 'M'	29342	62	O-ring S-5	10276
22	O-ring P-22A	10130	63	Cylinder cover 'M'	29359
23	B-ring P-22A	10131	64	O-ring P-10	10274
24	Back piston 'MV'	29663	65	O-ring P-6	10150
24U	Back piston unit 'MV'	29836	66	Change plug	29375
25	O-ring S-4	29664	67	Pan head tapping screw 4×20	29610
26	Nozzle (with O-ring)	29699	68	Cylinder bottom	29368
27	O-ring S-6	10220	69	Dust-proof cap	29611
28	Return spring 'M'	29345	70	Spool	29612
29	O-ring S-30	23685	71	O-ring P-5 (4D)	29613
30	Hanger clip 'M'	10106	72	O-ring P-8 (4D)	29614
31	Frame cap 'MV'	29666	73	Air hose unit	29448
31U	Frame cap unit 'MV'	29700	74	O-ring P-9	10219
32	O-ring P-10	10274	75	"LOBSTER" brand hydraulic oil	10012
33	Air valve (with O-rings)	29701	76	Spanner 'B'	29642
34	O-ring S-24	10185	77	Spanner 'A'	10141
35	Air controller (with O-ring)	29702	78	Cleaning brush	10143
36	O-ring P-30	14445	79	Hex key wrench 5 mm	25777
37	Pan head tapping screw 3×6	29670	80	Priming pump (syringe unit)	29624
38	Mandrel tank	29674			

* Part no. 14 includes part nos. 13, 15, 16, 19, 20, 41 and 42.
 Part no. 24U includes part nos. 22, 25, 26 and 27.

Part no. 31U includes part nos. 29, 30 and 32.
 Part no. 44 includes part nos. 19 and 20.

Part no. 58 includes part nos. 57 and 59.
 Part no. 73 includes part no. 74.

ORDERING PARTS

Indicate the tool model, part name, code no. and quantity as shown below when ordering.

Model	Part Name	Code No.	Qty.
AR2000MV	Ultra jaws (pair) 'M'	10281	1
AR2000MV	Frame head 'M'	29332	1

* When parts are modified for improvement, the older parts are kept in stock for a period of five years.