

---

# Center Bonded Mounts

**Featuring:** CB-1100 Series  
CB-1180 Series  
CBA Series  
CBA-50 Series  
STA Series  
Safetied Tubeform Series



Center Bonded Mounts isolate vibration, control shock and reduce noise due to structure borne vibrations. Available in a full range of rated load capacities and able to withstand shock loads of 10 g's, these mounts effectively protect equipment and improve operator comfort. They are ideal for automotive, marine, railroad and industrial markets.

Center Bonded Mounts provide flexible suspension systems for mobile, transport-mounted or portable equipment. Typical applications include engines, cabs, fuel tanks, pumps, air conditioning units, compressors and industrial machinery.

#### **Features and Benefits:**

- Vibration isolation in all directions.
- Noise attenuation.
- Easy installation because of one-piece design.
- Low-cost installation.
- Long service life.
- Consistent performance because of permanently bonded design.
- Shock protection in all directions provided by cushioned snubbing, no metal-to-metal bottoming.
- Standard sizes available from stock.
- Space-saving size.
- Captive installation after overload failure when recommended bolt, washer and nut are used.
- Accommodate English and Metric bolts.

#### **Application Engineering Assistance:**

Frequently, vibration isolation problems require a system engineering analysis. Lord has the computer capability, as well as specialized programs, for analyzing engine/transmission combinations. The output from this analysis is a mounting proposal which optimizes performance over the complete range of operating speeds. This service is available to you upon request.

# Center Bonded Mounts

## CB-1100 Series

Specifications and Dimensions: Table 1.

Part Number	Color Code	Maximum Axial Static Load Rating <sup>Ⓢ</sup>				Part Dimensions											
		Load		Deflection		A ± .03		B ± .01		C ± .015		D		E ± .015		F ± .02	
		lbs	N	in	mm	in	mm	in	mm	in	mm	in	mm	in	mm	in	mm
CB-1120-1 CB-1120-3	Blue —	75 125	330 560	.025 .025	.64 .64	1.09 1.09	27.7 27.7	.40 .40	10.2 10.2	.81 .81	20.6 20.6	1.02 1.02	25.9 25.9	.62 .62	15.7 15.7	.22 .22	5.6 5.6
CB-1121-2 CB-1121-4	Yellow —	250 450	1110 2000	.04 .04	1.02 1.02	1.75 1.75	44.5 44.5	.515 .515	13.1 13.1	1.24 1.24	31.5 31.5	1.25 1.25	31.8 31.8	1.00 1.00	25.4 25.4	.41 .41	10.4 10.4
CB-1122-2 CB-1122-4	Yellow —	350 600	1560 2670	.06 .06	1.52 1.52	2.00 2.00	50.8 50.8	.532 .532	13.5 13.5	1.35 1.35	34.3 34.3	1.62 1.62	41.1 41.1	1.31 1.31	33.3 33.3	.53 .53	13.5 13.5
CB-1123-2 CB-1123-5	Yellow —	500 1000	2230 4450	.07 .06	1.78 1.52	2.50 2.50	63.5 63.5	.648 .648	16.5 16.5	1.62 1.62	41.2 41.2	2.00 2.00	50.8 50.8	1.69 1.69	42.9 42.9	.62 .62	15.7 15.7
CB-1124-2 CB-1124-5 CB-1124-13	Yellow Orange —	750 1400 1250	3340 6230 5560	.085 .07 .085	2.16 1.78 2.16	2.98 2.98 2.98	75.7 75.7 75.7	.648 .648 .648	16.5 16.5 16.5	1.98 1.98 1.98	50.3 50.3 50.3	2.22 2.22 2.00	56.4 56.4 50.8	2.00 2.00 1.82	50.8 50.8 46.2	.81 .81 .81	20.6 20.6 20.6
CB-1125-2 CB-1125-4	Yellow —	1400 2100	6230 9350	.13 .12	3.30 3.05	3.74 3.74	95.0 95.0	.803 .803	20.4 20.4	2.23 2.23	56.6 56.6	2.48 2.48	63.0 63.0	2.00 2.00	50.8 50.8	1.00 1.00	25.4 25.4

Mounts and washers only supplied by Lord.  
For installation instructions, see P. 62.

<sup>Ⓢ</sup> These ratings are for general industrial applications. For on-highway use 80% of loads shown. For off-highway use 70% of loads shown.

In applications where the mounts will be immersed in oil, parts made in oil-resistant elastomer are available. Contact Lord Corporation for additional information.

## CB-1100 Series

Specifications and Dimensions: Table 2.

Part Number	Required Mating Directions												Recommended Bolt Information*				Nominal Dynamic — Static Spring Rate Ratio <sup>Ⓢ</sup>
	H ± .03		I <sub>D</sub> Min. Dia.		K <sub>D</sub> Min. Dia.		S <sub>D</sub> ± .03		T ± .03		R ± .015		Size		Grade or Class		
	in	mm	in	mm	in	mm	in	mm	in	mm	in	mm	English	Metric	SAE J429	SAE J1199	
CB-1120-1 CB-1120-3	.21 .21	5.3 5.3	1.25 1.25	31.8 31.8	1.12 1.12	28.5 28.5	.75 .75	19.1 19.1	.31 .31	7.9 7.9	.06 .06	1.5 1.5	3/8 3/8	M10 M10	2 2	5.8 5.8	1.08 1.19
CB-1121-2 CB-1121-4	.38 .38	9.7 9.7	2.00 2.00	50.8 50.8	1.50 1.50	38.1 38.1	1.12 1.12	28.4 28.4	.38 .38	9.7 9.7	.06 .06	1.5 1.5	1/2 1/2	M12 M12	2 2	5.8 5.8	1.15 1.22
CB-1122-2 CB-1122-4	.45 .45	11.4 11.4	2.25 2.25	57.2 57.2	2.00 2.00	50.8 50.8	1.25 1.25	31.8 31.8	.62 .62	15.8 15.8	.06 .06	1.5 1.5	1/2 1/2	M12 M12	2 2	5.8 5.8	1.15 1.22
CB-1123-2 CB-1123-5	.56 .56	14.2 14.2	2.88 2.88	73.2 73.2	2.25 2.25	57.2 57.2	1.50 1.50	38.1 38.1	.75 .75	19.1 19.1	.06 .06	1.5 1.5	5/8 5/8	M16 M16	8 8	10.9 10.9	1.15 1.23
CB-1124-2 CB-1124-5 CB-1124-13	.71 .71 .71	18.0 18.0 18.0	3.50 3.50 3.50	88.9 88.9 88.9	2.50 2.50 2.50	63.5 63.5 63.5	1.81 1.81 1.81	46.0 46.0 46.0	.93 .93 .75	23.6 23.6 19.1	.06 .06 .06	1.5 1.5 1.5	5/8 5/8 5/8	M16 M16 M16	8 8 8	10.9 10.9 10.9	1.15 1.23 1.23
CB-1125-2 CB-1125-4	.94 .94	23.9 23.9	4.25 4.25	108.0 108.0	3.00 3.00	76.2 76.2	2.00 2.00	50.8 50.8	.75 .75	19.1 19.1	.12 .12	3.0 3.0	3/4 3/4	M18 M18	8 8	10.9 10.9	1.15 1.22

For installation instructions, see P. 62.

\* For tightening torque information, see Pp.121 and 122.

This column of figures can be used to calculate <sup>Ⓢ</sup> dynamic spring rate for natural frequency based on static values.

$$(K_{DYN} = K_{ST} \times \frac{DYN}{STATIC} \text{ Ratio})$$

## Part Dimension

Figure 1

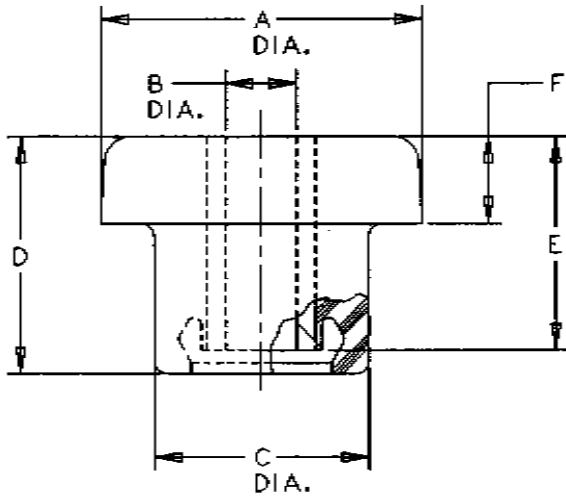

## Installation View

Figure 2

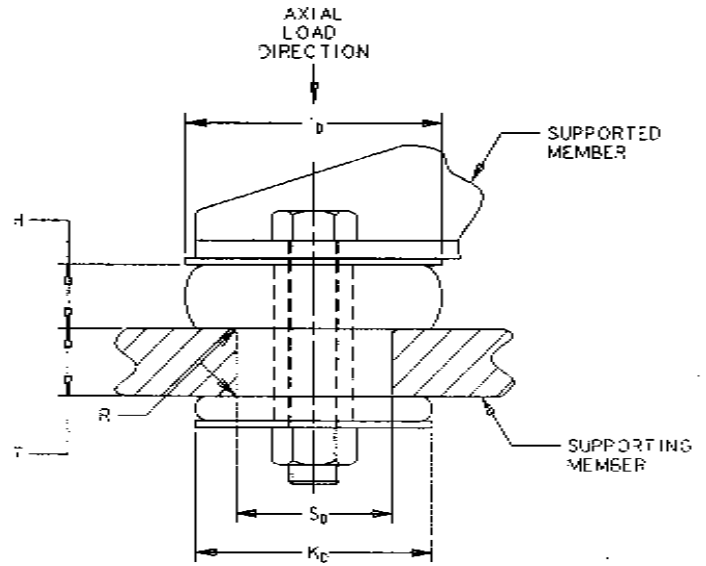

## CB-1100 Series

Washer Part Numbers and Dimensions: Table 3.

CB-1100 Series	Head Washer	O.D.		I.D.		Thk.		Tail Washer	O.D.		I.D.		Thk.	
		in	mm	in	mm	in	mm		in	mm	in	mm	in	mm
CB-1120	J-2049-62	1.25	31.8	.40	10.2	.125	3.2	J-2049-61	1.12	28.4	.40	10.2	.125	3.2
CB-1121	J-2049-64	2.00	50.8	.52	13.2	.125	3.2	J-2049-63	1.50	38.1	.52	13.2	.125	3.2
CB-1122	J-2049-65	2.25	57.2	.52	13.2	.125	3.2	J-2049-64	2.00	50.8	.52	13.2	.125	3.2
CB-1123	J-2049-68	2.88	73.2	.66	16.8	.125	3.2	J-2049-66	2.25	57.2	.64	16.3	.125	3.2
CB-1124	J-2049-70	3.50	88.9	.64	16.3	.190	4.8	J-2049-67	2.50	63.5	.64	16.3	.125	3.2
CB-1125	J-2049-71	4.25	108.0	.80	20.3	.190	4.8	J-2049-69	3.00	76.2	.80	20.4	.190	4.8

# Center Bonded Mounts

## CB-1180 Series

Specifications: Table 1.

Part Number	Maximum Axial Static Load Rating $\phi$				Part Dimensions											
	Load		Deflection		A		B		C		D		E		F	
	lbs	N	in	mm	in	mm	in	mm	in	mm	in	mm	in	mm	in	mm
CB-1180-1	400	1780	.135	3.4	2.50	63.1	.64	16.3	1.87	47.8	3.20	81.3	2.12	53.8	1.01	25.7
CB-1180-2	700	3115	.156	3.9	2.50	63.1	.64	16.3	1.87	47.8	3.20	81.3	2.12	53.8	1.01	25.7

$\phi$  These ratings are for general industrial applications. For on-highway use 80% of loads shown. For off-highway use 70% of loads shown.

For installation instructions, see P. 62.

## CB-1180 Series

Specifications: Table 2.

Part Number	Part Dimensions										Recommended Bolt Information*			
	H		I		$S_D \pm .03$		R		T		Size		Grade or Class	
	in	mm	in	mm	in	mm	in	mm	in	mm	English	Metric	SAE J429	SAE J1199
CB-1180-1	.87	22.1	1.625	41.3	1.50	38.1	.075	1.9	.75	19.1	5/8	M16	8	10.9
CB-1180-2	.87	22.1	1.625	41.3	1.50	38.1	.075	1.9	.75	19.1	5/8	M16	8	10.9

\* For tightening torque information, see Pp.121 and 122.

## Part Dimension

Figure 1

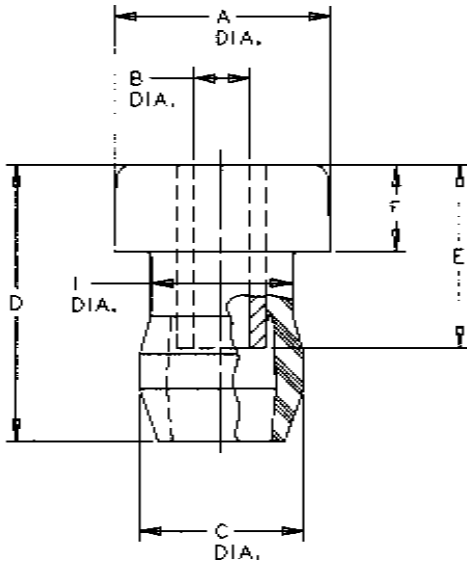

## Installation View (Shown under no load)

Figure 2

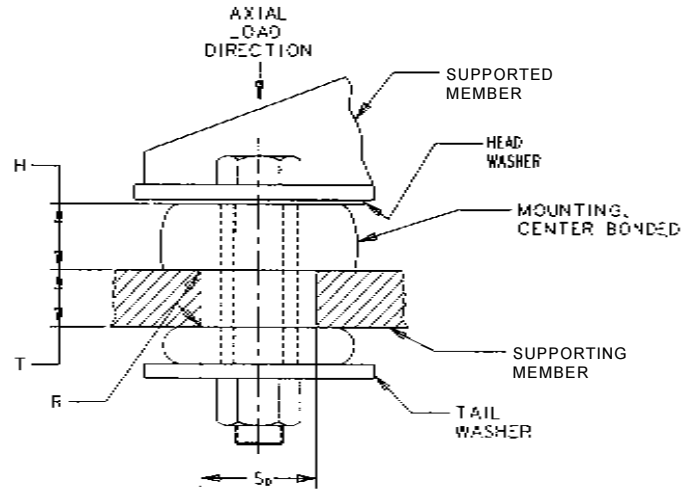

## CB-1180 Series

Washer Part Numbers and Dimensions: Table 3.

Part Number	Head Washer	O.D.		I.D.		Thk.		Tail Washer	O.D.		I.D.		Thk.	
		in	mm	in	mm	in	mm		in	mm	in	mm	in	mm
CB-1180-1	J-2049-68	2.88	73.2	.66	16.8	.125	3.2	J-2049-70	3.50	88.9	.64	16.3	.19	4.8
CB-1180-2	J-2049-68	2.88	73.2	.66	16.8	.125	3.2	J-2049-70	3.50	88.9	.64	16.3	.19	4.8

Mounts and washers only supplied by Lord.

# Center Bonded Mounts

## CBA Series

Specifications and Dimensions: Table 1.

Part Number	See Fig.	Color Code	Max. Axial Static Load Rating at Deflection $\ominus$		Part Dimensions											
			lbs at in	N at mm	A $\pm .015$		B		C $\pm .015$		D $\pm .02$		E $\pm .015$		F $\pm .02$	
					in	mm	in	mm	in	mm	in	mm	in	mm	in	mm
CBA12-100	1	—	100 at .09	445 at 2.3	1.25	31.8	.410	10.4	.95	24.1	1.44	36.6	1.07	27.2	.550	14.0
CBA12-200	1	Orange	200 at .09	890 at 2.3	1.25	31.8	.410	10.4	.95	24.1	1.44	36.6	1.07	27.2	.550	14.0
CBA20-300	1	—	300 at .09	1334 at 2.3	2.00	50.8	.540	13.5	1.38	35.1	2.00	50.8	1.45	36.8	.750	19.1
CBA20-300-1	2	—	300 at .09	1334 at 2.3	2.00	50.8	.545	13.5	1.38	35.1	2.00	50.8	1.45	36.8	.750	19.1
CBA20-400	1	Orange	400 at .10	1779 at 2.5	2.00	50.8	.540	13.5	1.38	35.1	2.00	50.8	1.45	36.8	.750	19.1
CBA20-400-1	2	Yellow	400 at .10	1779 at 2.5	2.00	50.8	.545	13.5	1.38	35.1	2.00	50.8	1.45	36.8	.750	19.1
CBA24-500	1	—	500 at .09	2224 at 2.3	2.35	59.7	.657	16.5	1.50	38.1	2.11	53.6	1.50	38.1	.690	17.5
CBA24-500-1	2	—	500 at .09	2224 at 2.3	2.35	59.7	.655	16.3	1.50	38.1	2.11	53.6	1.50	38.1	.690	17.5
CBA24-650	1	Orange	650 at .10	2891 at 2.5	2.35	59.7	.657	16.5	1.50	38.1	2.11	53.6	1.50	38.1	.690	17.5
CBA24-650-1	2	Yellow	650 at .10	2891 at 2.5	2.35	59.7	.655	16.3	1.50	38.1	2.11	53.6	1.50	38.1	.690	17.5
CBA28-800	1	—	800 at .10	3559 at 2.5	2.80	71.1	.810	20.3	1.62	41.1	2.38	60.5	1.63	41.4	.690	17.5
CBA28-800-1	2	—	800 at .10	3559 at 2.5	2.80	71.1	.785	19.6	1.62	41.1	2.38	60.5	1.63	41.4	.690	17.5
CBA28-1050	1	Orange	1050 at .10	4671 at 2.5	2.80	71.1	.810	20.3	1.62	41.1	2.38	60.5	1.63	41.4	.690	17.5
CBA28-1050-1	2	Yellow	1050 at .10	4671 at 2.5	2.80	71.1	.785	19.6	1.62	41.1	2.38	60.5	1.63	41.4	.690	17.5
CBA33-1200	1	—	1200 at .11	5338 at 2.8	3.30	83.8	.810	20.3	1.62	41.1	2.50	63.5	1.94	49.3	.880	22.4
CBA33-1200-1	2	—	1200 at .11	5338 at 2.8	3.30	83.8	.785	19.6	1.62	41.1	2.50	63.5	1.94	49.3	.880	22.4
CBA33-1600	1	Orange	1600 at .12	7117 at 3.0	3.30	83.8	.810	20.3	1.62	41.1	2.50	63.5	1.94	49.3	.880	22.4
CBA33-1600-1	2	Yellow	1600 at .12	7117 at 3.0	3.30	83.8	.785	19.6	1.62	41.1	2.50	63.5	1.94	49.3	.880	22.4

Mounts and washers supplied by Lord.

$\ominus$  These ratings are for general industrial applications. For on-highway use 80% of loads shown. For off-highway use 70% of loads shown.

## CBA Series

Specifications and Dimensions: Table 2.

Part Number	Installation Dimensions														Metal Parts $\ominus$
	H		I		K		L		S <sub>D</sub> $\pm .03$		R $\pm .015$		T $\pm .03$		
	in	mm	in	mm	in	mm	in	mm	in	mm	in	mm	in	mm	
CBA12-100	.51	13.0	1.50	38.1	1.50	38.1	—	—	.895	22.7	.06	1.5	.38	9.70	LCS
CBA12-200	.51	13.0	1.50	38.1	1.50	38.1	—	—	.895	22.7	.06	1.5	.38	9.70	LCS
CBA20-300	.69	17.5	2.38	60.5	2.25	57.2	—	—	1.25	31.8	.06	1.5	.50	12.7	LCS
CBA20-300-1	.69	17.5	2.38	60.5	2.25	57.2	1.38	35.1	1.25	31.8	.06	1.5	.50	12.7	HSS
CBA20-400	.69	17.5	2.38	60.5	2.25	57.2	—	—	1.25	31.8	.06	1.5	.50	12.7	LCS
CBA20-400-1	.69	17.5	2.38	60.5	2.25	57.2	1.38	35.1	1.25	31.8	.06	1.5	.50	12.7	HSS
CBA24-500	.62	15.7	2.75	69.9	2.50	63.5	—	—	1.38	35.1	.06	1.5	.62	15.7	LCS
CBA24-500-1	.62	15.7	2.75	69.9	2.50	63.5	1.62	41.1	1.38	35.1	.06	1.5	.62	15.7	HSS
CBA24-650	.62	15.7	2.75	69.9	2.50	63.5	—	—	1.38	35.1	.06	1.5	.62	15.7	LCS
CBA24-650-1	.62	15.7	2.75	69.9	2.50	63.5	1.62	41.1	1.38	35.1	.06	1.5	.62	15.7	HSS
CBA28-800	.63	16.0	3.25	82.6	3.00	76.2	—	—	1.50	38.1	.06	1.5	.75	19.1	LCS
CBA28-800-1	.63	16.0	3.25	82.6	3.00	76.2	1.62	41.1	1.50	38.1	.06	1.5	.75	19.1	HSS
CBA28-1050	.63	16.0	3.25	82.6	3.00	76.2	—	—	1.50	38.1	.06	1.5	.75	19.1	LCS
CBA28-1050-1	.63	16.0	3.25	82.6	3.00	76.2	1.62	41.1	1.50	38.1	.06	1.5	.75	19.1	HSS
CBA33-1200	.81	20.6	3.88	98.6	3.00	76.2	—	—	1.50	38.1	.06	1.5	.88	22.4	LCS
CBA33-1200-1	.81	20.6	3.88	98.6	3.00	76.2	1.62	41.1	1.50	38.1	.06	1.5	.88	22.4	HSS
CBA33-1600	.81	20.6	3.88	98.6	3.00	76.2	—	—	1.50	38.1	.06	1.5	.88	22.4	LCS
CBA33-1600-1	.81	20.6	3.88	98.6	3.00	76.2	1.62	41.1	1.50	38.1	.06	1.5	.88	22.4	HSS

$\ominus$  LCS = Low Carbon Steel  
HSS = High Strength Steel

For installation instructions, see P. 62.

## CBA Series

Specifications and Dimensions: Table 3.

Part Number	Recommended Bolt Information*				Nominal Dynamic — Static Spring Rate Ratio $\phi$
	Size		Grade or Class		
	English	Metric	SAE J429	SAE J1199	
CBA12-100	3/8	M10	2	5.8	1.08
CBA12-200	3/8	M10	2	5.8	1.22
CBA20-300	1/2	M12	2	5.8	1.15
CBA20-300-1	1/2	M12	8	10.9	1.15
CBA20-400	1/2	M12	2	5.8	1.19
CBA20-400-1	1/2	M12	8	10.9	1.19
CBA24-500	5/8	M16	2	5.8	1.15
CBA24-500-1	5/8	M16	8	10.9	1.15
CBA24-650	5/8	M16	2	5.8	1.19
CBA24-650-1	5/8	M16	8	10.9	1.19
CBA28-800	3/4	M18	2	5.8	1.15
CBA28-800-1	3/4	M18	8	10.9	1.15
CBA28-1050	3/4	M18	2	5.8	1.19
CBA28-1050-1	3/4	M18	8	10.9	1.19
CBA33-1200	3/4	M18	2	5.8	1.15
CBA33-1200-1	3/4	M18	8	10.9	1.15
CBA33-1600	3/4	M18	2	5.8	1.19
CBA33-1600-1	3/4	M18	8	10.9	1.19

## Standard Series (Uninstalled)

Figure 1

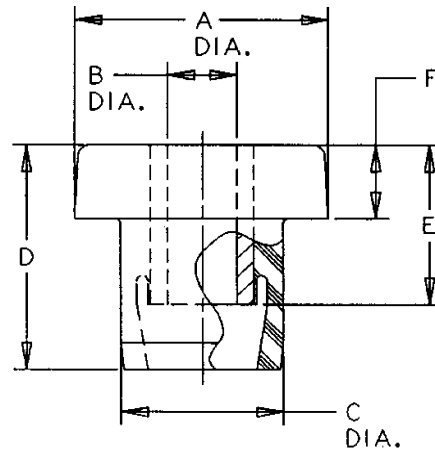

\* For tightening torque information, see Pp.121 and 122.

⊙ This column of figures can be used to calculate dynamic spring rate or natural frequency based on static values.

$$(K_{DYN} = K_{ST} \times \frac{DYN}{STATIC} \text{ Ratio})$$

## High Bolt Torque Series (-1 Parts, uninstalled, flanged inner member)

Figure 2

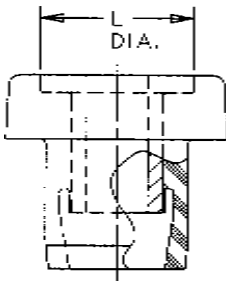

## Installation View (Shown under no load)

Figure 3

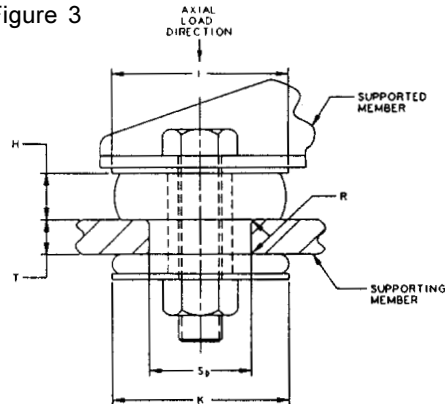

## CBA Series

Washer Part Numbers and Dimensions: Table 4.

CBA Series	Head Washer	O.D.		I.D.		Thk.		Tail Washer	O.D.		I.D.		Thk.	
		in	mm	in	mm	in	mm		in	mm	in	mm	in	mm
CBA12	J-2049-58	1.50	38.1	.42	10.7	.120	3.0	J-2049-58	1.50	38.1	.42	10.7	.120	3.0
CBA20	J-2049-52	2.38	60.5	.53	13.5	.125	3.2	J-2049-65	2.25	57.2	.52	13.2	.125	3.2
CBA24	J-2049-53	2.75	69.9	.64	16.3	.125	3.2	J-2049-67	2.50	63.5	.64	16.3	.125	3.2
CBA28	J-2049-54	3.25	82.6	.80	20.3	.188	4.8	J-2049-69	3.00	76.2	.80	20.3	.188	4.8
CBA33	J-2049-55†	3.88	98.6	.80	20.3	.188	4.8	J-2049-69	3.00	76.2	.80	20.3	.188	4.8

Washers must be ordered separately.

† Non-Stock Item, please contact Lord Corporation for availability.

# Center Bonded Mounts

## CBA-50 Series

Specifications and Dimensions: Table 1.

Part Number ❶	Max. Axial Static Load Rating at Deflection ❷		Typical Spring Rates				Metal Bracket Part Number ❸	Part Dimensions									
			Axial		Radial			A		B		C		D			
	lbs at in	N at mm	lbs/in	N/mm	lbs/in	N/mm		in	mm	in	mm	Dia. Min.		Dia. Max.		in	mm
												in	mm	in	mm		
CBA12-100-50	100 at .09	445 at 2.3	1110	194	1300	228	Y-30266-5-1	2.38	60.5	.44	11.2	.404	10.3	.412	10.5	1.75	44.5
CBA12-200-50	200 at .09	890 at 2.3	2220	389	3000	525	Y-30266-5-1	2.38	60.5	.44	11.2	.404	10.3	.412	10.5	1.75	44.5
CBA20-300-50	300 at .12	1334 at 3.0	2500	438	3500	613	Y-30266-4-1	3.75	95.2	.50	12.7	.404	10.3	.412	10.5	2.25	57.2
CBA20-400-50	400 at .12	1780 at 3.0	3300	578	4300	753	Y-30266-4-1	3.75	95.2	.50	12.7	.404	10.3	.412	10.5	2.25	57.2
CBA24-500-50	500 at .12	2224 at 3.0	4200	736	5300	927	Y-30266-3-1	4.25	108.0	.50	12.7	.404	10.3	.412	10.5	2.50	63.5
CBA24-650-50	650 at .12	2891 at 3.0	5400	945	7500	1313	Y-30266-3-1	4.25	108.0	.50	12.7	.404	10.3	.412	10.5	2.50	63.5

All metal parts are made of low carbon steel.

❶ Mount and washer only furnished by Lord.

❷ These ratings are for general industrial applications. For on-highway use 80% of loads shown. For off-highway use 70% of loads shown.

❸ If you require a high bolt torque series or any other special part, use metal bracket part number and the CBA part number found on page 54 or contact the application department for assistance.

## CBA-50 Series

Specifications and Dimensions: Table 2.

Part Number ❶	Part Dimensions																											
	E						F	G	H	I	J	K	M Min. ❷	N	S <sub>D</sub> ± .03	T												
	I.D. Min.		I.D. Max.		O.D.											in	mm	in	mm	in	mm	in	mm	in	mm	in	mm	in
	in	mm	in	mm	in	mm	in	mm	in	mm	in	mm	in	mm	in													
CBA12-100-50	.397	10.1	.410	10.4	.50	12.7	2.25	57.2	.61	15.5	.06	1.5	1.25	31.8	1.07	27.2	1.25	31.8	1.50	38.1	.57	14.5	1.38	35.1	.19	4.8	.25	6.40
CBA12-200-50	.397	10.1	.410	10.4	.50	12.7	2.25	57.2	.61	15.5	.06	1.5	1.25	31.8	1.07	27.2	1.25	31.8	1.50	38.1	.57	14.5	1.38	35.1	.19	4.8	.25	6.40
CBA20-300-50	.525	13.3	.540	13.7	.75	19.0	3.00	76.2	.85	21.6	.10	2.5	2.00	50.8	1.45	36.8	1.92	48.8	2.38	60.5	.79	20.1	2.00	50.8	.25	6.4	.38	9.70
CBA20-400-50	.525	13.3	.540	13.7	.75	19.0	3.00	76.2	.85	21.6	.10	2.5	2.00	50.8	1.45	36.8	1.92	48.8	2.38	60.5	.79	20.1	2.00	50.8	.25	6.4	.38	9.70
CBA24-500-50	.639	16.2	.657	16.7	.88	22.3	3.50	88.9	.82	20.8	.13	3.3	2.35	59.7	1.50	38.1	2.19	55.6	2.75	69.9	.76	19.3	2.25	57.2	.38	9.7	.50	12.7
CBA24-650-50	.639	16.2	.657	16.7	.88	22.3	3.50	88.9	.82	20.8	.13	3.3	2.35	59.7	1.50	38.1	2.19	55.6	2.75	69.9	.76	19.3	2.25	57.2	.38	9.7	.50	12.7

❶ Bracket must provide support in excess of M Dia. Min., otherwise a washer is required. Washer must be ordered separately.

❷ Minimum supporting member thickness for high rebound load capacities.

❸ Maximum supporting member thickness for all applications.

## Part Dimension

Figure 1

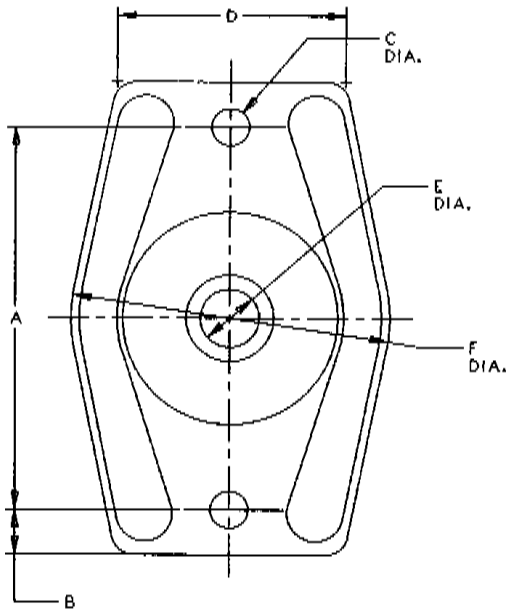

## Installation View (Shown under no load)

Figure 2

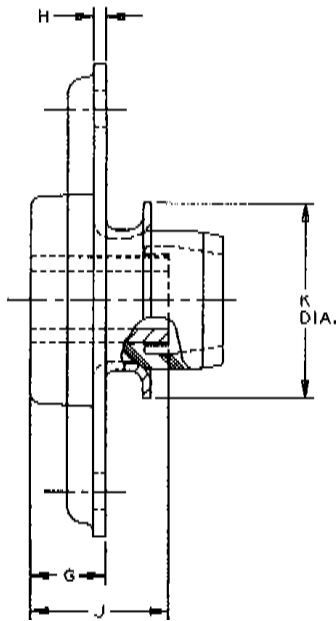
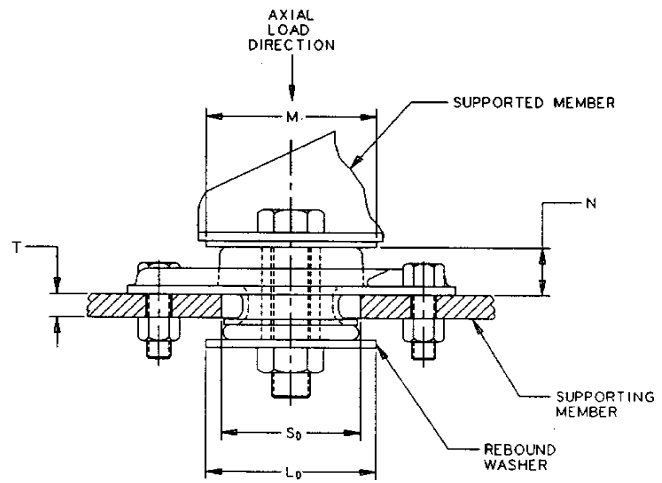

## CBA-50 Series

Washer Part Numbers and Dimensions: Table 3.

CBA-50 Series	Washer Part Number	O.D.		I.D.		Thk.	
		in	mm	in	mm	in	mm
CBA12	J-2049-58	1.50	38.1	.42	10.7	.120	3.0
CBA20	J-2049-52	2.38	60.5	.53	13.5	.125	3.2
CBA24	J-2049-53	2.75	69.9	.64	16.3	.125	3.2

# Center Bonded Mounts

## STA Series

Specifications and Dimensions: Table 1.

Part Number ①	Max. Axial Static Load Rating ②		Axial Static Spring Rate		Radial Static Spring Rate		Part Dimensions									
							A		B		C		D		E	
	lbs	N	lbs/in	N/mm	lbs/in	N/mm	in	mm	in	mm	in	mm	in	mm	in	mm
STA30-200-1	200	890	2800	490	3,000	525	3.12	79.4	3.00	76.2	.770	19.6	1.25	31.8	.81	20.6
STA30-300-1	300	1330	3700	645	4,500	788	3.12	79.4	3.00	76.2	.770	19.6	1.25	31.8	.81	20.6
STA30-400-1	400	1780	5000	870	8,000	1,401	3.12	79.4	3.00	76.2	.770	19.6	1.25	31.8	.81	20.6
STA36-500-1	500	2220	4300	750	12,500	2,189	3.75	95.3	3.62	92.0	1.020	25.9	1.50	38.1	1.05	26.7
STA36-600-1	600	2670	6100	1060	15,000	2,627	3.75	95.3	3.62	92.0	1.020	25.9	1.50	38.1	1.05	26.7
STA36-700-1	700	3110	7000	1220	20,000	3,503	3.75	95.3	3.62	92.0	1.020	25.9	1.50	38.1	1.05	26.7

Part Number	Part Dimensions																	
	F		G		H		J		K		L		S <sub>D</sub> ± .03		R		T	
	in	mm	in	mm	in	mm	in	mm	in	mm	in	mm	in	mm	in	mm	in	mm
STA30-200-1	.63	16.0	1.56	39.6	2.25	57.2	2.34	59.4	2.345	59.4	.69	17.3	2.380	60.5	3.25	82.6	.62	15.7
STA30-300-1	.63	16.0	1.56	39.6	2.25	57.2	2.34	59.4	2.345	59.4	.69	17.3	2.380	60.5	3.25	82.6	.62	15.7
STA30-400-1	.63	16.0	1.56	39.6	2.25	57.2	2.34	59.4	2.345	59.4	.69	17.3	2.380	60.5	3.25	82.6	.62	15.7
STA36-500-1	.72	18.3	2.03	51.6	2.80	71.1	2.47	62.7	2.470	62.70	.96	24.4	2.500	63.5	4.00	101.6	.75	19.1
STA36-600-1	.72	18.3	2.03	51.6	2.80	71.1	2.47	62.7	2.470	62.70	.96	24.4	2.500	63.5	4.00	101.6	.75	19.1
STA36-700-1	.72	18.3	2.03	51.6	2.80	71.1	2.47	62.7	2.470	62.70	.96	24.4	2.500	63.5	4.00	101.6	.75	19.1

① Mount assembly only furnished by Lord Corporation.

Tolerances : .xx = ± .03 in. (± .762 mm)  
.xxx = ± .015 in. (± .381 mm)

Part Number	Recommended Bolt Information*				Rebound Washer Part Number
	Size		Grade or Class		
	English	Metric	SAE J429	SAE J1199	
STA30-200-1	3/4	M18	8	10.9	J-2049-54
STA30-300-1	3/4	M18	8	10.9	J-2049-54
STA30-400-1	3/4	M18	8	10.9	J-2049-54
STA36-500-1	1	M24	8	10.9	J-2049-76
STA36-600-1	1	M24	8	10.9	J-2049-76
STA36-700-1	1	M24	8	10.9	J-2049-76

\* For tightening torque information, see Pp.121 and 122.

② Ratings are the same for on-highway, off-highway and general industrial use.

Material and Finish:

Mounting: Natural rubber, non oil-resistant, low carbon steel, corrosion resistant coated.

Rebound Washer: Steel, zinc plated  
Mounts are designed to be loaded in the axial direction only.  
If bracket provides support equal to top rebound washer, Diameter A top rebound washer is not required.

Bottom rebound washer is required for all installations; see tabulation for part number.

STA30-200-1 to STA30-400-1

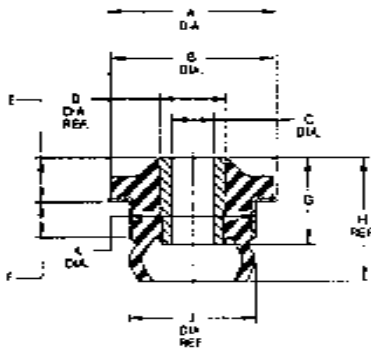

Part Dimensions

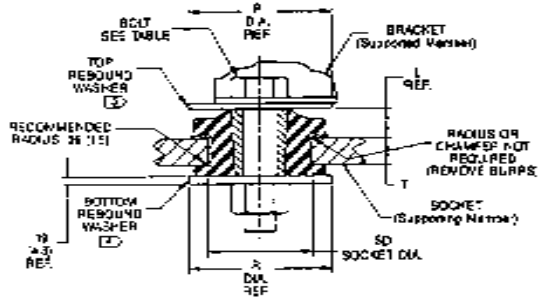

Installation View  
(Shown Under No Load)

STA36-500-1 to STA36-700-1

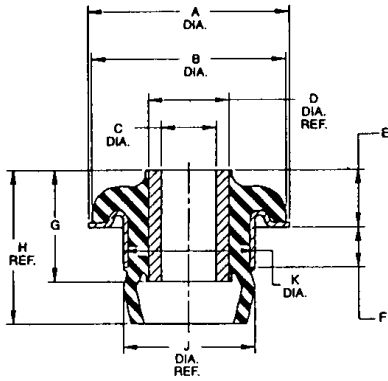

Part Dimensions

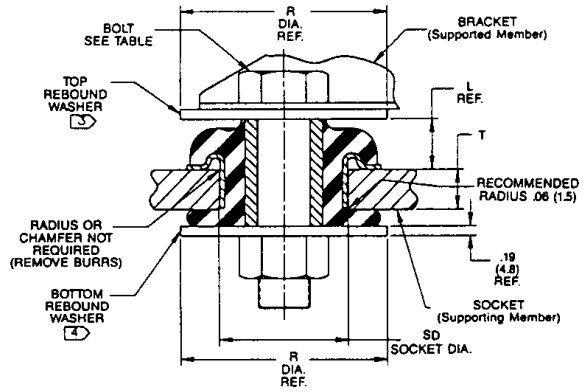

Installation View  
(Shown Under No Load)

# Center Bonded Mounts

## Safetied Tube Form Series

Specifications and Dimensions: Table 1.

Part Number	Elastomer <sup>①</sup>	Color Code <sup>②</sup>	Axial Static Load				Radial Static Load				Axial Static Deflection at Nominal Load		Part Dimensions			
			Nominal		Maximum		Nominal		Maximum				A		B	
			lbs	N	lbs	N	lbs	N	lbs	N	in	mm	in	mm	in	mm
J-20595-1†	NR	R	320	1423	480	2135	160	712	320	1423	.10	2.5	5.25	133.4	4.25	108.0
J-20595-2†	NR	Y	380	1690	570	2535	190	845	380	1690						
J-20595-3†	NR	G	460	2046	690	3069	230	1023	460	2046						
J-20595-4†	NR	B	560	2490	840	3736	280	1245	560	2490						
J-20595-5†	NR	P	680	3025	1020	4537	340	1512	680	3025						
J-20595-11†	OR	R & W	320	1423	480	2135	160	712	320	1423	.10	2.5	5.25	133.4	4.25	108.0
J-20595-12†	OR	Y & W	380	1690	570	2535	190	845	380	1690						
J-20595-13†	OR	G & W	460	2046	690	3069	230	1023	460	2046						
J-20595-14†	OR	B & W	560	2490	840	3736	280	1245	560	2490						
J-20595-15†	OR	P & W	680	3025	1020	4537	340	1512	680	3025						
J-18748-21†	NR	R	460	2046	690	3069	230	1023	460	2046	.10	2.5	6.25	158.8	5.00	127.0
J-18748-22†	NR	Y	560	2490	840	3736	280	1245	560	2490						
J-18748-23†	NR	G	680	3025	1020	4537	340	1512	680	3025						
J-18748-24†	NR	B	830	3692	1245	5538	415	1846	830	3692						
J-18748-25†	NR	P	1000	4448	1500	6672	500	2224	1000	4448						
J-18748-26†	OR	R & W	460	2046	690	3069	230	1023	460	2046	.10	2.5	6.25	158.8	5.00	127.0
J-18748-27	OR	Y & W	560	2490	840	3736	280	1245	560	2490						
J-18748-28	OR	G & W	680	3025	1020	4537	340	1512	680	3025						
J-18748-29	OR	B & W	830	3692	1245	5538	415	1846	830	3692						
J-18748-30	OR	P & W	1000	4448	1500	6672	500	2224	1000	4448						
J-18787-11†	NR	R	830	3692	1245	5538	415	1846	830	3692	.10	2.5	7.50	190.5	6.00	152.4
J-18787-12†	NR	Y	1000	4448	1500	6672	500	2224	1000	4448						
J-18787-13†	NR	G	1210	5382	1815	8073	605	2691	1210	5382						
J-18787-14†	NR	B	1470	6539	2205	9808	735	3269	1470	6539						
J-18787-15†	NR	P	1780	7918	2700	12,010	890	3959	1780	7918						
J-18787-16	OR	R & W	830	3692	1245	5538	415	1846	830	3692	.10	2.5	7.50	190.5	6.00	152.4
J-18787-17†	OR	Y & W	1000	4448	1500	6672	500	2224	1000	4448						
J-18787-18	OR	G & W	1210	5382	1815	8073	605	2691	1210	5382						
J-18787-19†	OR	B & W	1470	6539	2205	9808	735	3269	1470	6539						
J-18787-20†	OR	P & W	1780	7918	2700	12,010	890	3959	1780	7918						

Mounts and washers only supplied by Lord Corporation.

① NR = Natural Rubber  
OR = Oil Resistant, Neoprene

② Color Codes: R = Red R & W = Red & White  
Y = Yellow Y & W = Yellow & White  
G = Green G & W = Green & White  
B = Blue B & W = Blue & White  
P = Purple P & W = Purple & White

† Non-Stock Item, please contact Lord Corporation for availability.

Recommended Washer Dimensions: Table 2.

Series Number	Part Dimensions					
	O.D.		I.D.		Thk.	
	in	mm	in	mm	in	mm
J-20595	2.25	57.2	.64	16.3	.125	3.2
J-18748	2.50	63.5	.760	19.3	.188	4.8
J-18787	3.25	82.6	1.01	25.7	.250	6.4

Mounts and washers only supplied by Lord Corporation.

Specifications and Dimensions: Table 3.

Part Dimensions																		Recommended Bolt Information*			
C		D		E		F		G		H		I		S <sub>D</sub>		T		Size		Grade or Class	
in	mm	in	mm	in	mm	in	mm	in	mm	in	mm	in	mm	in	mm	in	mm	English	Metric	SAE J429	SAE J1199
.687	17.4	.406	10.3	2.75	69.9	2.25	57.2	1.18	30.0	.125	3.2	2.25	57.2	2.62	66.5	.69	17.5	5/8	M16	8	10.9
.687	17.4	.406	10.3	2.75	69.9	2.25	57.2	1.18	30.0	.125	3.2	2.25	57.2	2.62	66.5	.69	17.5	5/8	M16	8	10.9
.778	19.8	.531	13.5	3.38	85.9	3.00	76.2	1.38	35.1	.190	4.8	2.50	63.6	2.88	73.2	1.25	31.8	3/4	M18	8	10.9
.778	19.8	.531	13.5	3.38	85.9	3.00	76.2	1.38	35.1	.190	4.8	2.50	63.6	2.88	73.2	1.25	31.8	3/4	M18	8	10.9
1.065	27.1	.656	16.7	4.38	111.3	4.00	101.6	1.50	38.1	.250	6.4	3.30	83.8	3.75	95.3	2.00	50.8	1	M24	8	10.9
1.065	27.1	.656	16.7	4.38	111.3	4.00	101.6	1.50	38.1	.250	6.4	3.30	83.8	3.75	95.3	2.00	50.8	1	M24	8	10.9

\* For tightening torque information, see Pp.121 and 122.

### Installation View (Shown under no load)

Figure 1

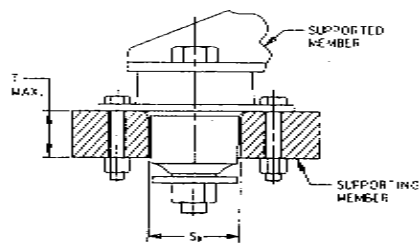

### Part Dimensions

Figure 2

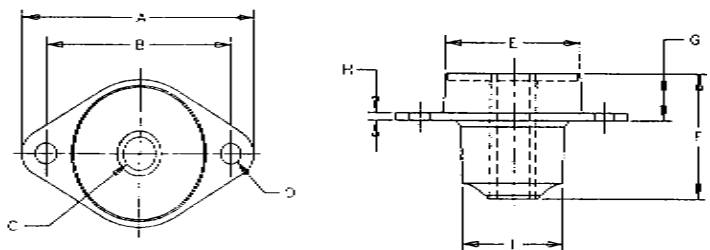

---

# Center Bonded Mounts

## Installation Guide

---

### Specifications

**Materials:** The elastomers are high quality natural rubber which meet Lord specifications (available upon request).

The elastomer-to-metal bonds are stronger than the elastomer.

**Environmental:** For applications in severe oil environments, contact Lord Corporation. Based on extensive experience, center bonded mounts have been designed to operate in normal fluid, temperature and other environmental conditions such as found in the engine compartment of on- and off-highway applications.

**Testing/Quality Control:** Drawings of each part specify the load deflection tests which are performed to assure consistency of spring rate characteristics.

**Testing/Performance:** Extensive laboratory fatigue testing has been performed under simulated service conditions.

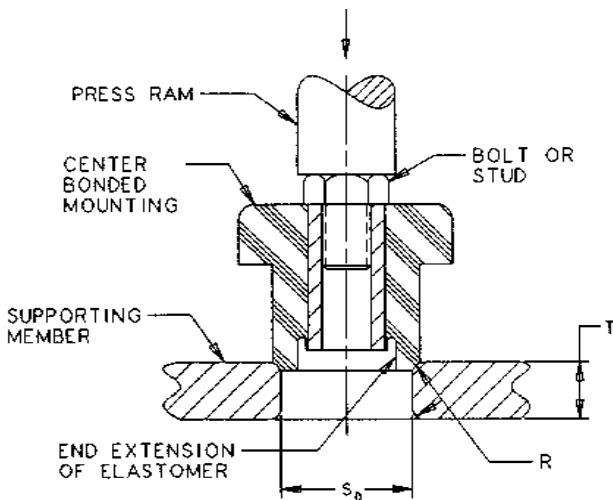

### Installation

Installation is simple, consisting of four steps:

1. Both mount and socket should be lightly lubricated with rubber lubricant or water. A special rubber lubricant, P-80 Emulsion, is available from International Products Corporation, P.O. Box 70, Burlington, NJ 08016-0070, Phone: (609) 386-8770, FAX: (609) 386-8438.
2. Insert part in socket and rotate part by hand while applying axial force until partially positioned. Insert assembly driver in the metal inner member of the mount. Care should be taken that the driving device does not overhang the outside diameter of the inner member in order to prevent damage to the elastomer.
3. Apply pressure to the driving device to seat the mount in its socket.
4. Assemble the other elements of the support, insert the mount bolt and tighten to the required torque. When the nut is tightened against the snubbing washer, the rebound shoulder is formed automatically. The resulting pre-compression assures optimum performance.